



## Perfect welding fume extraction now within easy reach!

It is a health hazard when the concentration of welding fumes is too high in the working area. Welders perform better in a clean and healthy environment where they know that they are optimally protected from these hazards. Good welding fume extraction results in a higher productivity and a lower absentee rate.

Euromate provides an innovative solution for all kinds of welding activities at any location.

### **The new PHV is a leap forward**

Euromate has created yet another technological breakthrough by introducing the PHV. This portable unit is ahead of its time on performance, design and ease of handling, fulfilling both current and future requirements. The PHV can be used everywhere, also in locations that are not or hardly accessible to stationary units or to the larger mobile welding fume extraction units.



## PORTABLE WELDING FUME EXTRACTOR (PHV)

Breathe free **Breathe Euromate®**



## The welder's profes

Euromate's PHV is a user-friendly, portable unit on wheels that is used to provide efficient welding fume extraction at source. It is compact and light and easy to handle and use. Pre-eminently suitable for on-site light to moderate welding jobs, in confined spaces or at difficult to reach welding locations.

### Incomparable to the conventional portable units:

- **Innovative design**

The auto start/stop device automatically switches the PHV on when welding takes place. Its weight is minimal due to the use of impact-resistant synthetic components.

The standard set of wheels on the PHV allows easy movement of the unit.

- **Unique price-quality ratio**

The PHV is equipped with a Dura-H® main filter and a HEPA final filter, an auto start/stop device and two powerful forced-cooling motors and two

extraction capacities. Its sound insulation is excellent.

- **Dura-H® filter technique**

The unique Dura-H® main filter has a surface area of no less than 12 m<sup>2</sup>. This results in a longer life and consistently high filtration efficiency without the need to clean the filter. Once the Dura-H filter is fully contaminated with particulate material, the complete cartridge can be disposed off cleanly and safely without exposing the operator to the pollutant.

- **Four-stage filtration system**

The welding fumes enter the unit via a metal pre-separator and flow through, consecutively, the aluminium pre-filter, the Dura-H® main filter, an optional activated carbon filter and a HEPA filter.

This final filter before the clean air leaves the unit guarantees a filtration efficiency of 99.9% under all circumstances.

**Two motors**

**Low noise level**

**Standard set of wheels**

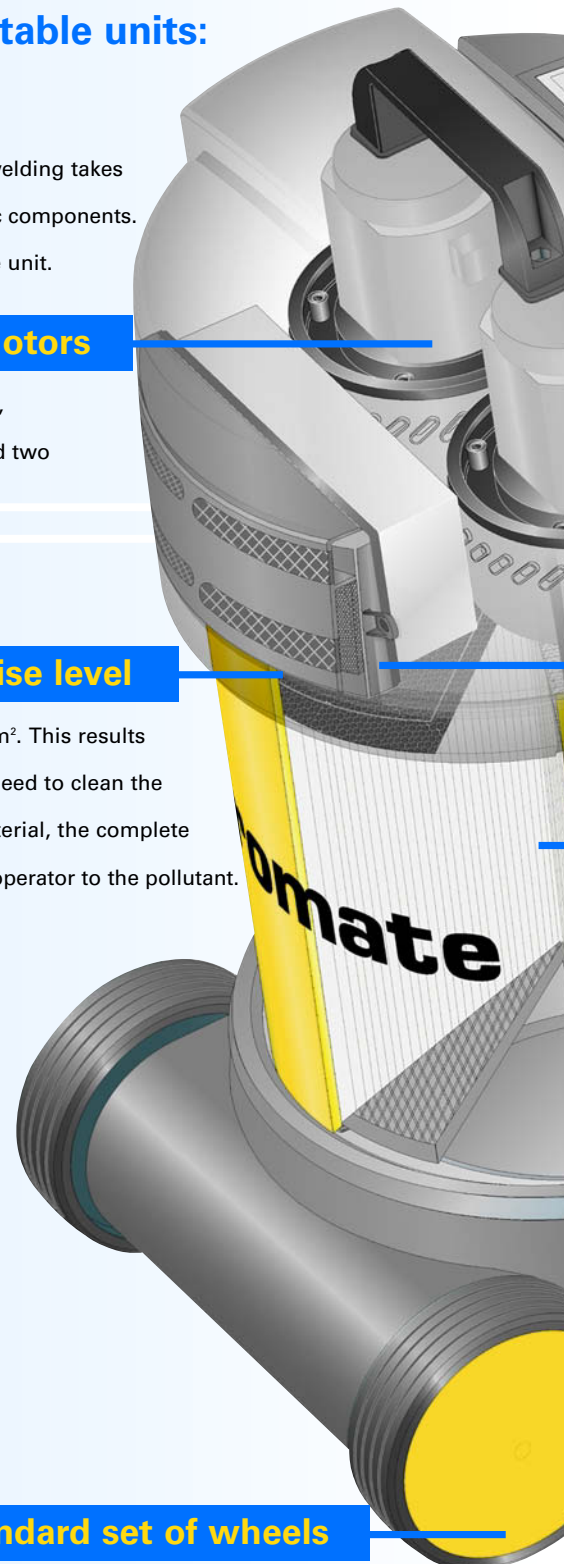

# sional aid

## • Low noise level

No effort was spared to ensure that the PHV is as quiet as possible. A smart sound insulation material is fitted into the air exhaust that provides a significant sound reduction without affecting the motor cooling.



Auto start/stop

HEPA filter

Dura-H® filter



## • Two powerful motors

The two motors guarantee an adequate extraction capacity under all conditions. At low welding fume concentrations, the extraction capacity can be halved and both motors operate at half speed with the following advantages: a constant motor load, a lower noise level and reduced maintenance. The forced-cooling allows a continuous use of the PHV.

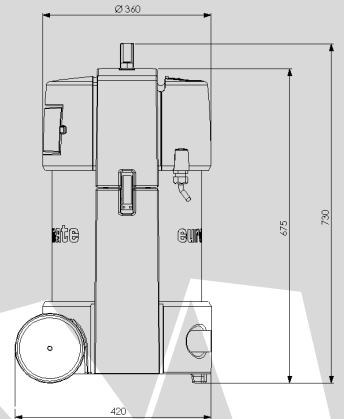

## Technical specifications

- Number of motors: 2
- Motor power consumption: 2 x 1kW
- Automatic start/stop device: standard
- Power supply: 115V/monophase/50-60 Hz  
230V/monophase/50-60 Hz
- Max. extraction capacity: position 1 - 160 m<sup>3</sup>/h  
position 2 - 230 m<sup>3</sup>/h
- Noise level with extraction torch installed: 70 dB(A)
- Main filter with spark arrester: 12 m<sup>2</sup>
- Final filter: HEPA, filter class H12
- Filter efficiency: 99,9%
- Activated carbon filter: optional
- Set of wheels: standard
- Weight: 15 kg
- Clogged filter indicator and BIA-W3: optional (PHV-I)



## PHV accessories



Extraction nozzle EN-40 for max. 40 cm electrodes.



Hose length 2.5 m H 2,5/45.  
Hose length 5 m H 5,0/45.



Nozzle kits to provide extraction facility on standard welding torches; type NKT for top-extraction and type NKC for annular extraction.



Hose connection HCH 45 to dispose filtrated welding fumes, e.g. when welding stainless steel.



Funnel extraction nozzle EN-20.



Activated carbon filter FAC HV to neutralise smells.



Wall mounting bracket MBH.

## Euromate: innovation in welding fume extraction

The Portable High Vacuum (PHV) unit is one of the products in Euromate's new generation of the revolutionary innovative Pro Line® welding fume extraction range. Pro Line® means: innovative technology, efficiency and user-friendliness. Euromate offers tailor made solutions with a unique price-quality ratio for every particular welding process at any welding location.

Expert advice and information is available from:

Maahantuonti, markkinointi ja huolto:

**OY SONESTA AB**

Salmitie 3, 02430 Masala, puhelin (09) 825 6160, faksi (09) 878 7699  
eMail: info@sonesta.fi www.sonesta.fi



### Euromate BV

Wezelkoog 11

1822 BL Alkmaar – The Netherlands

Tel. +31 72 5640634

Fax +31 72 5644469

E-mail: info@euromate.nl

Internet: www.euromate.com